

SPECIFICATIONS

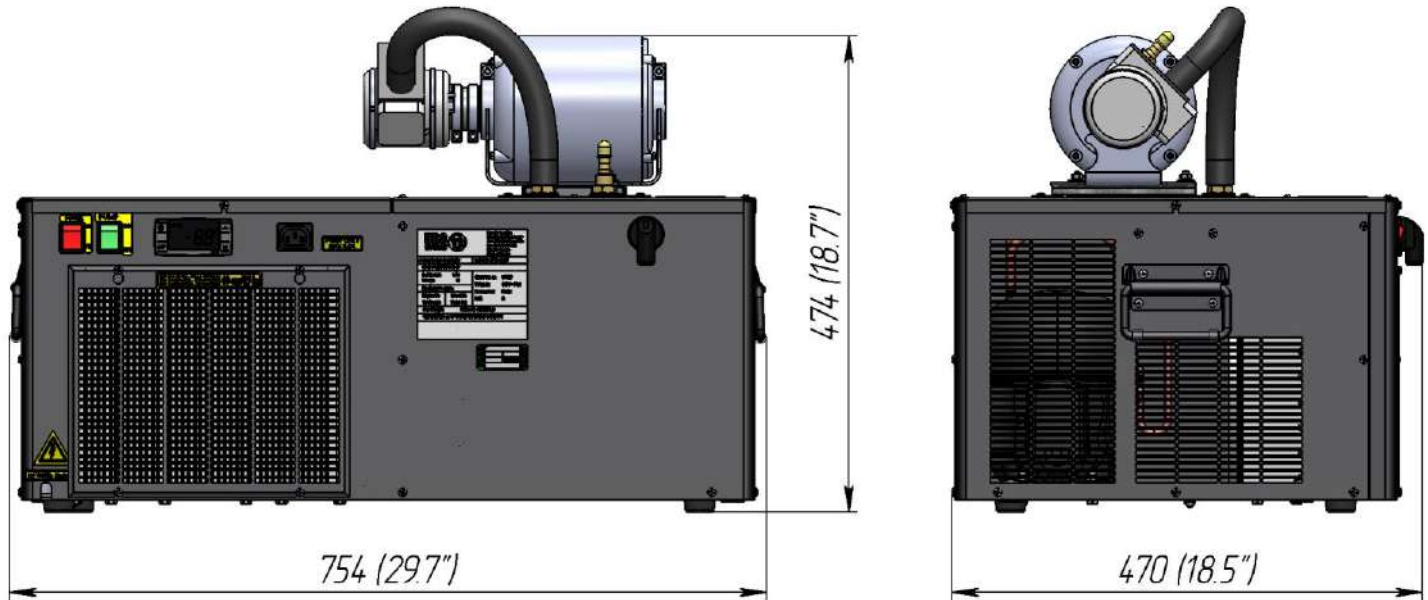

Internal number	148.00.000.00-XX
Part number	CP3200H
Maximum distance, ft	up to 125
Capacity, BTU/h, evap 20 °F	3200
Glycol tank capacity, gal	5.8
Compressor power, hp	3/8
Dedicated circuit, amp	20
Plug type (NEMA #)	5-20P 
Voltage, V / frequency, Hz	115 / 60
Pump type	Vane with 1/3 hp motor
Pump, GPH	80
Number of pre-installed pumps	1
Number of additional pumps	n/a
Refrigerant	R290
Width, in	29.7
Depth, in	18.5
Height, in	18.7 / 24 (on optional legs)
Weight gross/net, lb	102 / 91
Power cord length, ft	6
Inlet/Outlet barb, in	3/8
Operating ambient temperature, °F	60-90
Clearance at least	12" around the entire unit
Glycol mixture, vol%	40 % glycol and 60% water

OVERALL DIMENSIONS



WIRING DIAGRAM

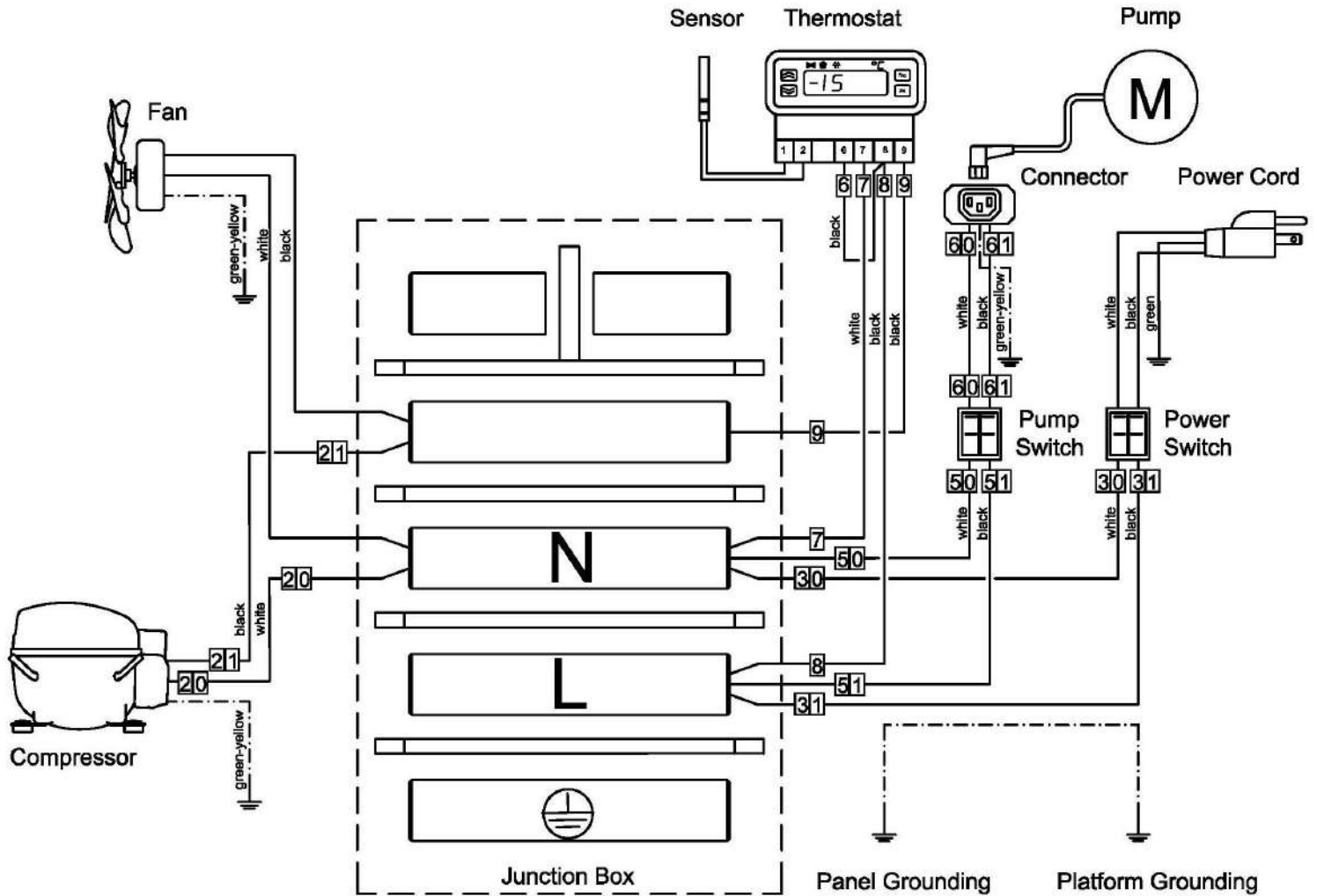

**PARTS**

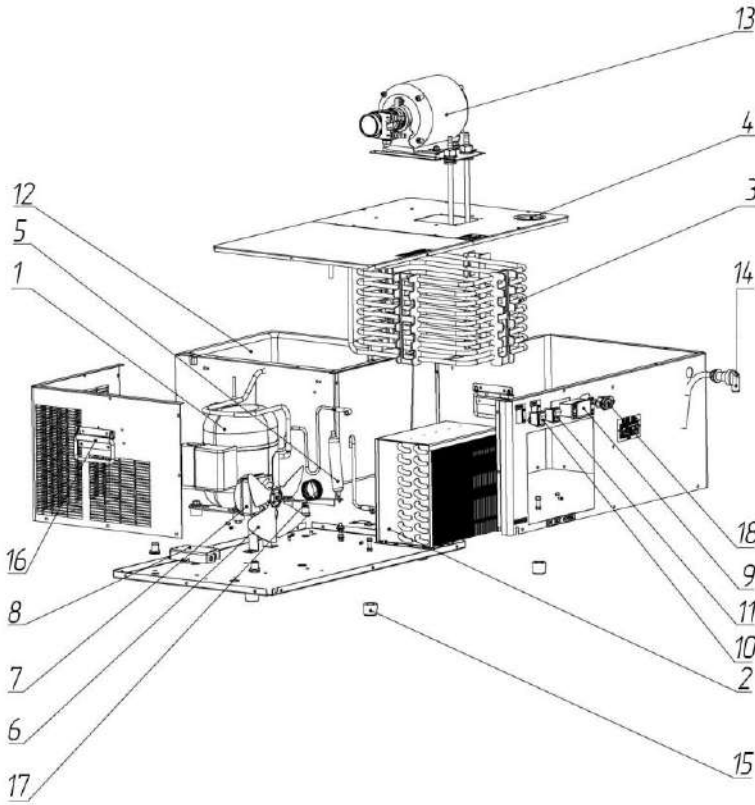

1	Compressor "Cubigel" NLY90RRa (115-127V/60Hz) or "Secop" NLE8.8CN (115-127V/60Hz)
2	Air condenser "KARYER" B-18143 UL
3	Evaporator
4	Cap
5	Filter-drier "DE-NA" GR-15 d6.1xd6.1xd2.5
6	Impeller Ø200 mm., $\alpha=28^\circ$
7	Electric motor "ELCO" NU 9-20-2/094 (115V/50-60Hz) UL "WGMotors" YZF10-20-26 (10W)(110-120V/60Hz) or "EBM" M4Q045-CA-27-04 (115V/60Hz)
8	Terminal block "ITW ELETTRGIBI " PA104
9	Thermostat "DIXELL" XR02CX-4N0F1 (115 V/ 60Hz)
10	Power switch "ARCOLECTRIC" C6053ALBR (Red)
11	Power switch "ARCOLECTRIC" C6053ALBG (Green)
12	Glycol bath
13	Glycol pump «FLUID-O-TECH» PA 2501 or "PROCON" 102A080F11BA250, and motor "MARATHON" 5KH32FN5586MX (115V/60Hz) or "UBC" YU250-4G01 (100-120V/200-240V-50/60hz)
14	Overflow
15	Foot
16	Handle
17	Capillary tube 2.4x0.575x1800 mm
18	Connector R302SN 250V 10A